

DIXON

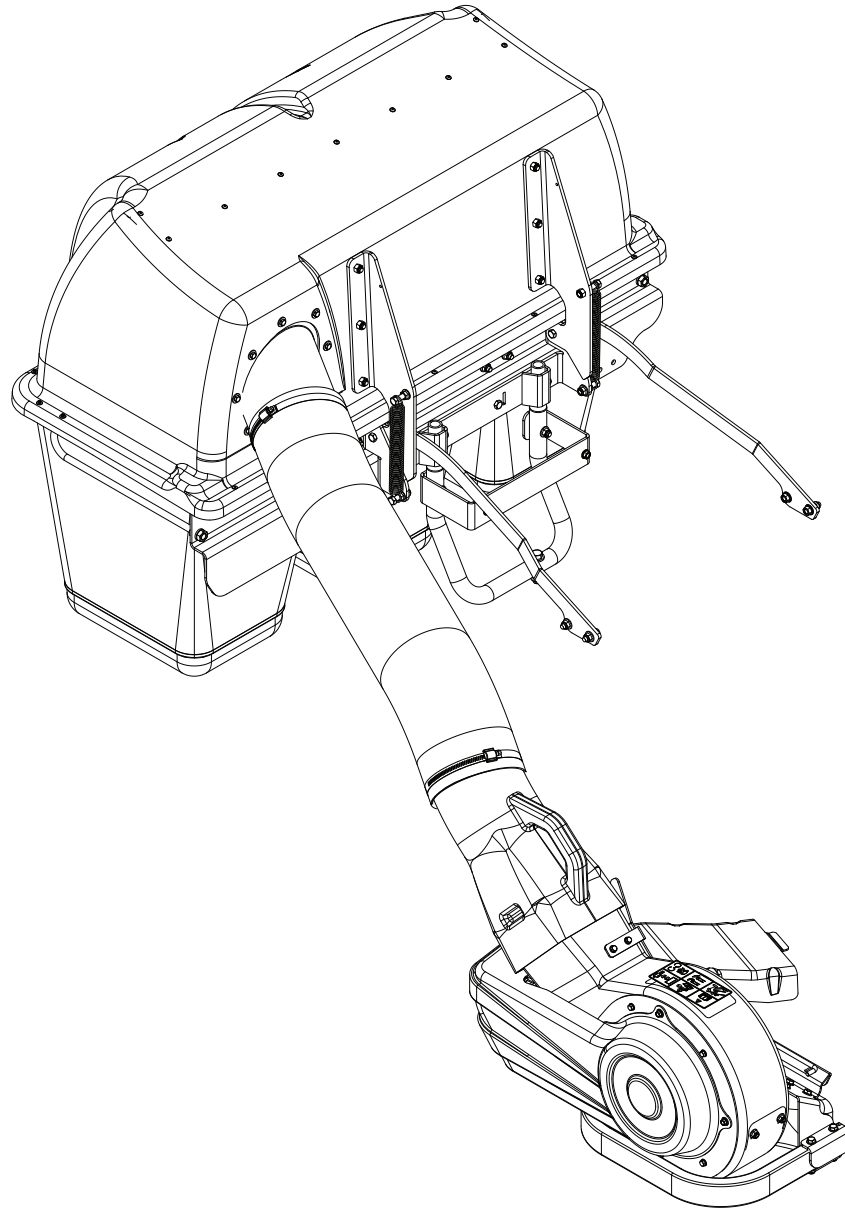

COLLECTION SYSTEM Operator Manual Parts Manual

966 004901

Please read these instructions carefully and make sure you understand them before using the machine.



WARNING!

Engine exhaust, some of its constituents, and certain vehicle components contain or emit chemicals known to the State of California to cause cancer and birth defects or other reproductive harm.

CONTENTS

COMPONENTS	4	SERVICE AND MAINTENANCE.....	14
SAFETY RULES	5	TRANSPORT	14
GENERAL OPERATION.....	5	STORAGE	14
SLOPE OPERATION.....	5	HOSE CARE.....	14
CHILDREN	6	BAG CARE	14
SERVICE	6	POLY MESH CLEANING.....	14
ASSEMBLY	8	PREVENTATIVE MAINTENANCE SCHEDULE	15
BAGGER ASSEMBLY	8	TROUBLESHOOTING GUIDE	15
DRIVE PULLEY	10	OPERATION	16
TRIMMING BLOWER	10	TIPS FOR IMPROVED BAGGING	16
BLOWER ASSEMBLY	11	CUSTOMER RESPONSIBILITIES.....	17
DRIVE BELT	11	HOOD	18
BELT COVERS	12	HITCH	20
MIDDLE CHUTE.....	12	BLOWER.....	22
WEIGHT KIT.....	13	WEIGHT.....	24
		COLLECTION BAG.....	24
		DRIVE KIT.....	26

CONGRATULATIONS on your purchase of a new Grass Catcher. It has been designed, engineered and manufactured to give you the best possible dependability and performance.

Should you experience any problem you cannot easily remedy, contact the nearest authorized service center/ department. They have competent, well-trained technicians and the proper tools for service and repairs.

Read and retain this manual. The instructions will enable you to assemble and maintain your collection system properly. Always observe the SAFETY RULES.

KNOW YOUR GRASS CATCHER

READ THIS OPERATION MANUAL AND SAFETY RULES BEFORE ASSEMBLING OR OPERATING YOUR GRASS CATCHER. Compare the illustrations with the carton contents to familiarize yourself with the parts before starting the assembly. Study the operating instructions and safety precautions thoroughly to insure proper functioning of your Grass Catcher and to prevent injury to yourself and others. Save this manual for future reference.



WARNING!

The operation of any mower can result in foreign objects thrown into the eyes, which can result in severe eye damage. ALWAYS wear safety glasses or eye shields before starting your mower and while mowing. We recommend a wide vision safety mask for over the spectacles or standard safety glasses.

COMPONENTS

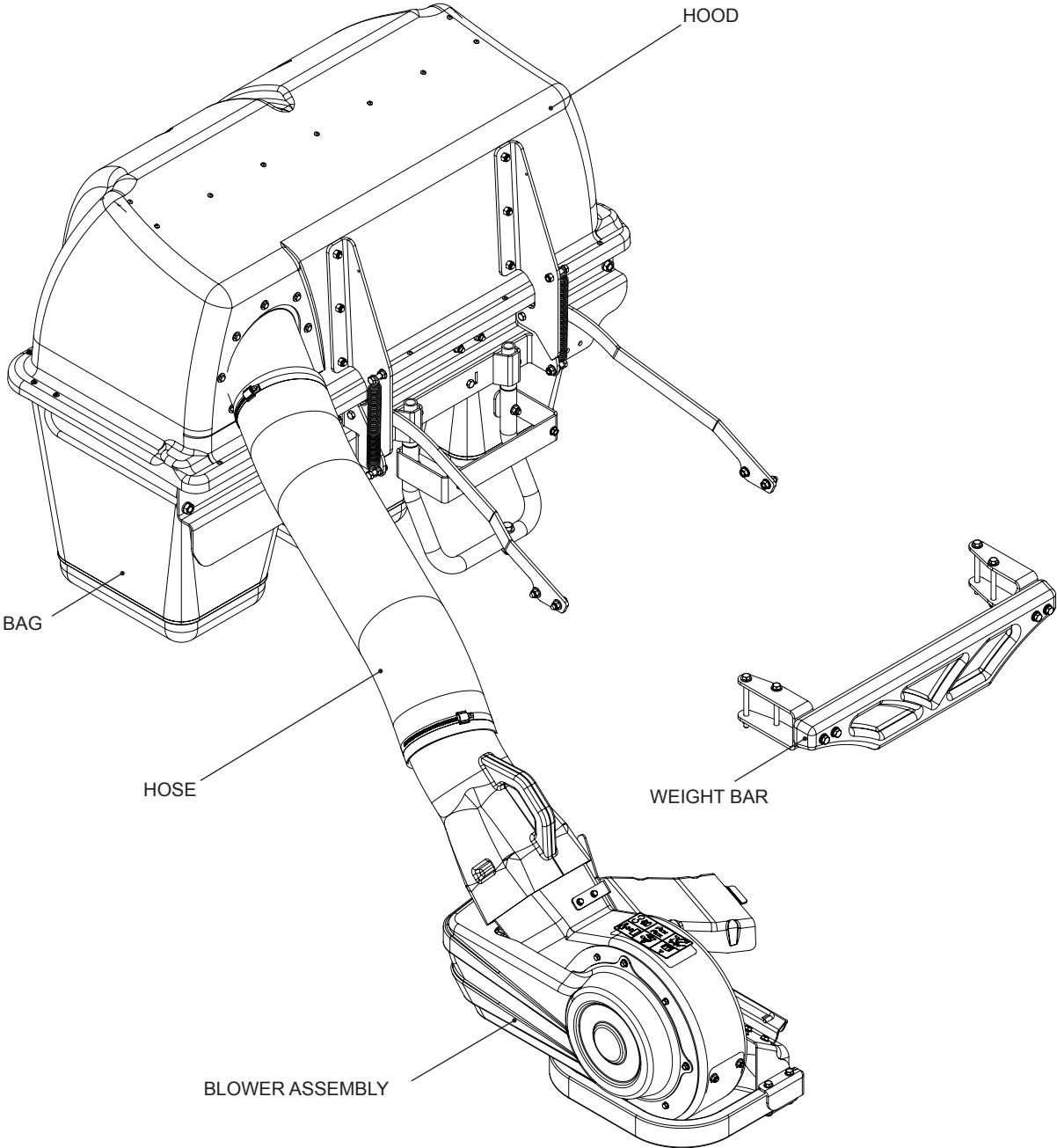

NOTE: Front Weight Bars vary by model and may look different from those shown.

SAFETY RULES



SAFE OPERATION PRACTICES FOR RIDE-ON MOWERS



DANGER !

THIS CUTTING MACHINE IS CAPABLE OF AMPUTATING HANDS AND FEET AND THROWING OBJECTS. FAILURE TO OBSERVE THE FOLLOWING SAFETY INSTRUCTIONS COULD RESULT IN SERIOUS INJURY OR DEATH.

GENERAL OPERATION

- Read, understand and follow all instructions in the manual and on the machine before starting.
- Only allow responsible adults, who are familiar with the instructions, to operate the machine.
- Clear the area of objects such as rocks, stones, toys, wire etc., which could be picked up and thrown by the blades.
- Be sure the area is clear of all people and pets before mowing. Stop the machine if anyone enters the area.
- Never carry passengers or children even with blades off.
- Do not mow in reverse unless absolutely necessary. Always look down and behind before and while backing.
- Be aware of the mower discharge direction and do not direct it towards anyone. Do not operate the mower without either the entire grass catcher or the guard in place.
- Slow down before turning.
- Never leave the machine unattended when the engine is running. Always turn off the blades, set the parking brake, stop the engine and remove the key before leaving the machine.
- Turn off blades when not mowing.
- Stop engine before removing grass catcher or unclogging chute.
- Mow only in daylight or good artificial light.
- Do not operate the machine while under the influence of alcohol or drugs.
- Watch out for traffic when operating near or crossing roadways.
- Use extra care when loading and unloading the machine onto a trailer or truck.

- Data indicates that operators, age 60 years and above, are involved in a large percentage of riding mower-related injuries. These operators should evaluate their ability to operate the riding mower safely enough to protect themselves and others from serious injury.
- **DO NOT** operate mower with grass catcher, unless the front weights are installed.
- Keep machine free of grass, leaves or other debris buildup which can touch hot exhaust/engine parts and burn. Do not allow the mower deck to plow leaves or other debris which can cause buildup to occur. Clean any oil or fuel spillage before operating or storing the machine. Allow machine to cool before storage.

SLOPE OPERATION

Slopes are a major factor related to loss-of-control and tipover accidents, which can result in severe injury or death. All slopes require extra caution. If you cannot back up the slope or if you feel uneasy on it, do not mow it.

DO

- Mow up and down slopes (10° Max.), not across.
- Remove obstacles such as rocks, tree limbs, etc.
- Watch for holes, ruts, or bumps. Uneven terrain could overturn the machine. **Tall grass can hide obstacles.**
- Use slow speed. Choose a low speed so that you will not have to stop while on the slope.
- Use extra care with grass catchers or other attachments. These can change the stability of the machine.
- Keep all movement on the slopes **slow** and **gradual**. Do not make sudden changes in speed or direction.
- Avoid starting or stopping on a slope. If tires lose traction, disengage the blades and proceed slowly **straight** down the slope.

SAFETY RULES



SAFE OPERATION PRACTICES FOR RIDE-ON MOWERS



DO NOT

- **Do not** turn on slopes unless necessary, and then, turn slowly and gradually downhill, if possible.
- **Do not** mow near drop-off, ditches, or embankments. The mower could suddenly turn over if a wheel is over the edge of a cliff or ditch, or if an edge caves in.
- **Do not** mow on wet grass. Reduced traction could cause sliding.
- **Do not** try to stabilize the machine by putting your foot on the ground.

CHILDREN

Tragic accidents can occur if the operator is not alert to the presence of children. Children are often attracted to the machine and the mowing activity. Never assume that children will remain where you last saw them.

- **NEVER allow children to operate the machine.**
- Keep children out of the mowing area and under the watchful care of another responsible adult.
- Be alert and turn off the machine if children enter the area.
- Before and when backing, look behind and **down** for small children.
- Never carry children. They may fall off and be seriously injured or interfere with safe machine operation.
- Use extra care when approaching blind corners, shrubs, trees, or other objects that may obscure vision.

SERVICE

- The operation of any mower can result in foreign objects thrown into the eyes, which can result in severe eye damage. Always wear safety glasses or eye shields while operating your mower or performing any adjustments or repairs. We recommend a wide vision safety mask over spectacles or standard safety glasses.

- Use extra care in handling gasoline and other fuels. They are flammable and vapors are explosive.
 - Use only an approved container.
 - Never remove gas cap or add fuel with the engine running.
 - Allow engine to cool before refueling.
 - Do not smoke.
 - Never refuel the machine indoors.
 - Never store the machine or fuel container inside where there is an open flame, such as a water heater.
- Never run a machine inside a closed area.
- Keep nuts and bolts, especially blade attachment bolts, tight and keep equipment in good condition.
- Never tamper with safety devices. Check for proper operation regularly.
- Keep machine free of grass, leaves, or other debris buildup. Clean oil or fuel spillage. Allow machine to cool before storing.
- Stop and inspect the equipment if you strike an object. Repair, if necessary, before restarting.
- Never make adjustments or repairs with the engine running.
- Grass catcher components are subject to wear, damage, and deterioration, which could expose moving parts or allow objects to be thrown. Frequently check components and replace with manufacturer's recommended parts, when necessary.
- Mower blades are sharp and can cut. Wrap the blade(s) or wear gloves, and use extra caution when servicing them.
- Check brake operation frequently. Adjust and service as shown in the Operator's Manual.

SAFETY RULES



SAFE OPERATION PRACTICES FOR RIDE-ON MOWERS



- **NEVER allow children to operate the machine.**
- Be sure the area is clear of other people before mowing. Stop machine if anyone enters the area.
- Never carry passengers or children even with the blades off.
- Do not drive in reverse unless absolutely necessary. Always look down and behind before and while backing.
- Never carry children. They may fall off and be seriously injured or interfere with safe machine operation.
- Keep children out of the mowing area and under the watchful care of another responsible adult.
- Be alert and turn machine off if children enter the area.
- Before and when backing, look behind and down for small children.
- Mow up and down slopes (10° Max), not across.
- Remove obstacles such as rocks, tree limbs, etc.
- Watch for holes, ruts, or bumps. Uneven terrain could overturn the machine. Tall grass can hide obstacles.
- Use a slow speed while on slope or hill.
- Avoid starting or stopping on a slope. If tires lose traction, disengage the blades and proceed slowly straight down the slope.
- If machine stops while going uphill, disengage blades, shift into reverse and back down slowly.
- Do not turn on slopes unless necessary, and then, turn slowly and gradually downhill, if possible.



CAUTION
Look for this symbol to point out important safety precautions. It means **CAUTION! BECOME ALERT! YOUR SAFETY IS INVOLVED.**



CAUTION

In order to prevent accidental starting when setting up, transporting, adjusting or making repairs, always disconnect spark plug wire and place wire where it cannot contact spark plug.



WARNING!

Engine exhaust, some of its constituents, and certain vehicle components contain or emit chemicals known to the State of California to cause cancer and birth defects or other reproductive harm.



WARNING!

Battery posts, terminals and related accessories contain lead and lead compounds, chemicals known to the State of California to cause cancer and birth defects or other reproductive harm. Wash hands after handling.

ASSEMBLY

BAGGER ASSEMBLY

1. Attach hitch tube to support bracket with $\frac{3}{8}$ -16 x 2 shoulder bolts and secure with flange nuts.

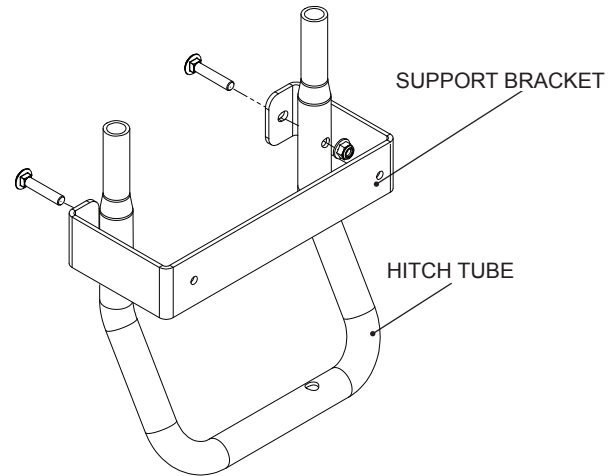

2. Place the support bracket against the frame rear guard. Using the outer right hole and inner left hole, secure with $\frac{5}{16}$ x 1 bolts and $\frac{5}{16}$ nyloc nuts.
3. Attach support tube to frame hitch with $\frac{1}{2}$ x 2 $\frac{1}{4}$ bolt and $\frac{1}{2}$ nyloc nut.

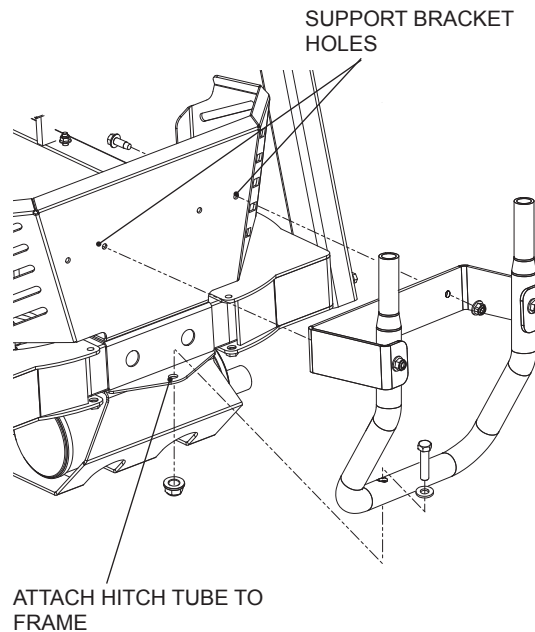

4. Place the hood / hitch assembly onto the hitch tube.
5. Open the hood and secure the (2) springs to the bolts on the hood assembly and the hitch assembly.

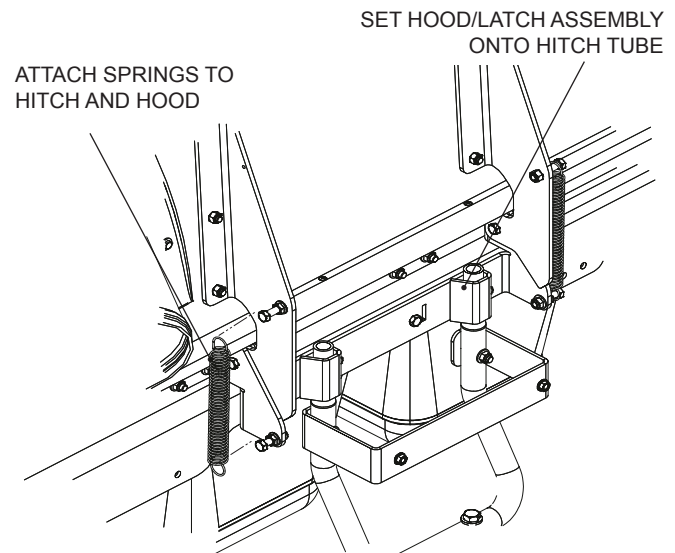

ASSEMBLY

6. Attach right and left straps to the hood/latch assembly with $\frac{3}{8}$ -16 x 1 bolts and flange nuts.

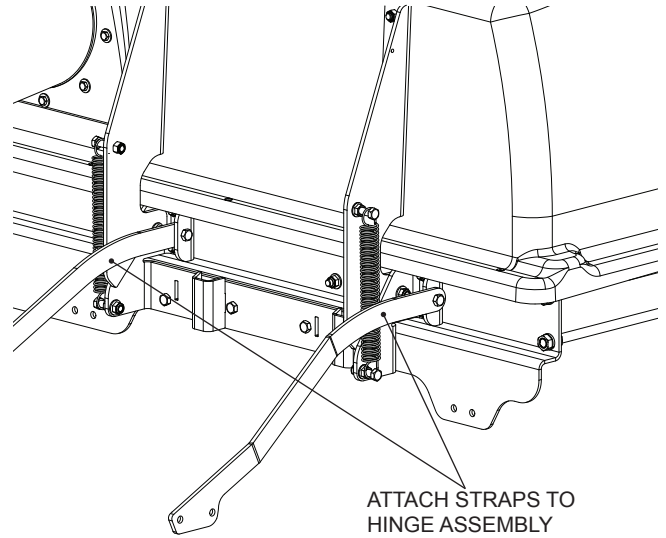

9. Secure inner end of straps to unit fuel tank mounts with $\frac{3}{8}$ -16 x 1 thread forming bolts and flange nuts, as shown.

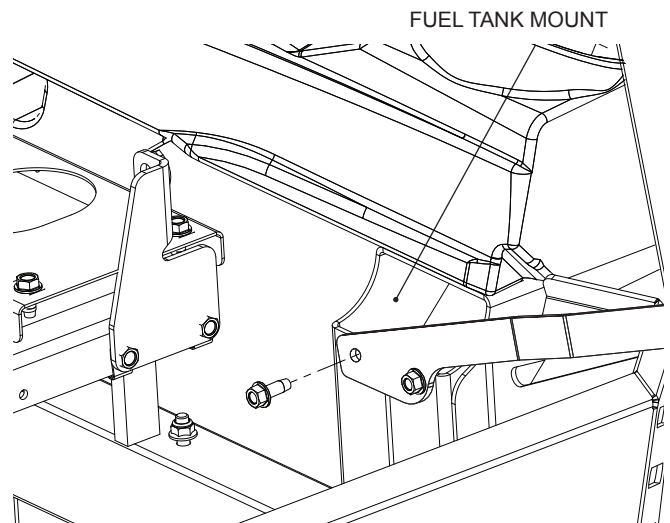

10. With the hood open, secure the (3) bags in place. The back of the bags will hook over the mounting tabs on the hitch assembly.
11. Close the hood, and lock the draw latch over the draw latch keeper on the hitch assembly.

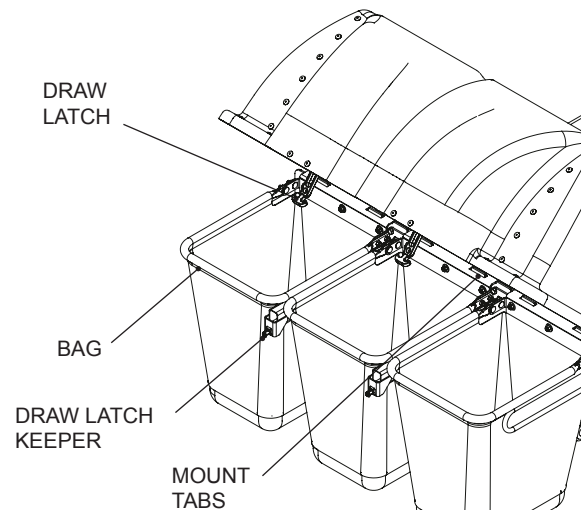

ASSEMBLY

DRIVE PULLEY

1. Remove the discharge chute from the deck. (Deck configuration will vary by size and model)
2. Lower deck to the lowest cutting position.
3. Remove the right hand (discharge side) belt cover from the deck.
4. Relieve the tension from the deck belt and remove from the center deck pulley.
(See Operator's Manual if necessary)

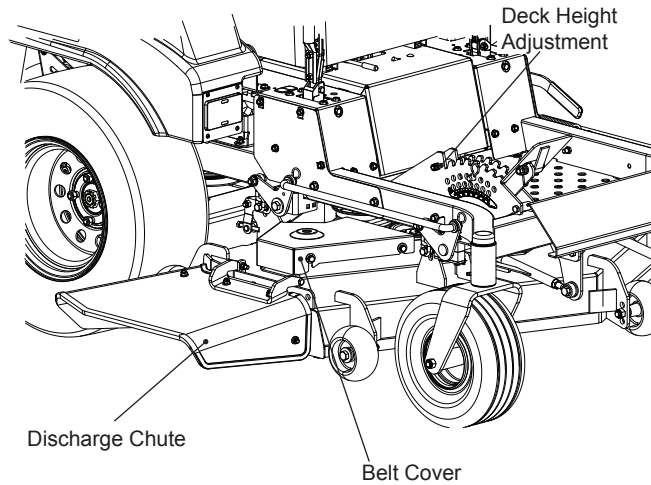

5. Remove the nut that secures the right hand deck pulley to the spindle.
6. Install drive pulley included in collection system kit on top of the current deck pulley.
7. Reinstall the nut on the spindle and torque to 55-75 ft/lbs.
8. Reinstall the deck belt.

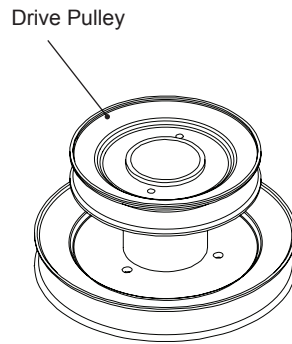

DECK STOP

1. Locate the deck stop behind the rear lift link on each side of the deck.
2. Set deck stop tube on the deck stop on each side.

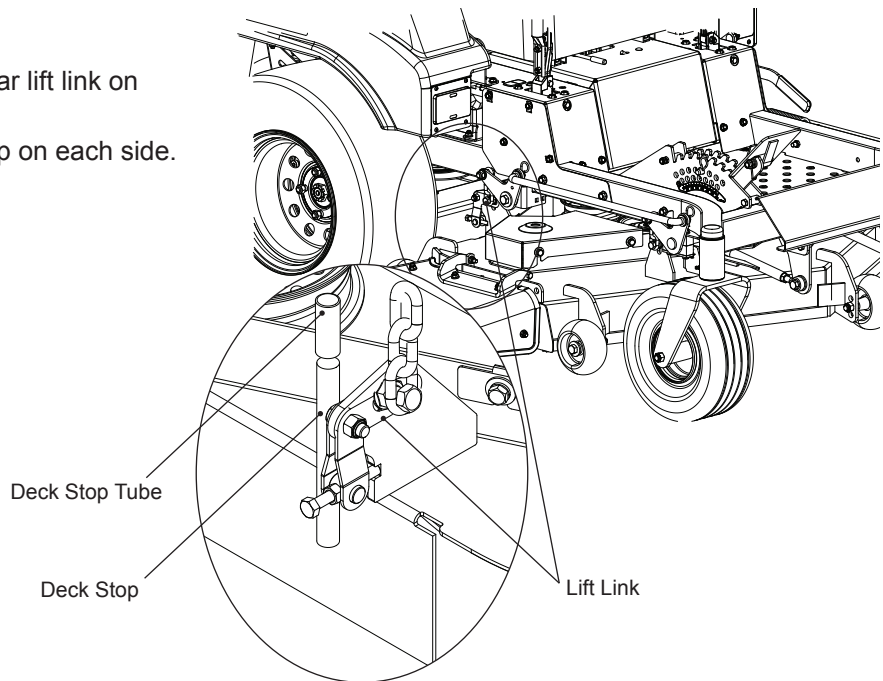

ASSEMBLY

BLOWER ASSEMBLY

1. Position blower over the discharge tabs on the deck and set blower onto the deck.
2. Be sure the blower is sitting flush against the outside of the deck.
3. Secure the mount bracket to the deck with the pin and hairpin cotter supplied with the kit.

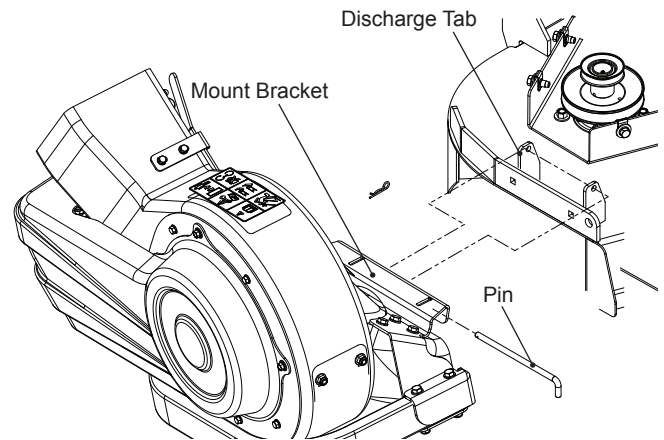

DRIVE BELT

1. Make sure the tension release lever is forward or disengaged.
2. Place the belt over the pulley on the deck. Refer to illustration for proper routing.
3. Move the tension release arm to the rear and engage in the latch.

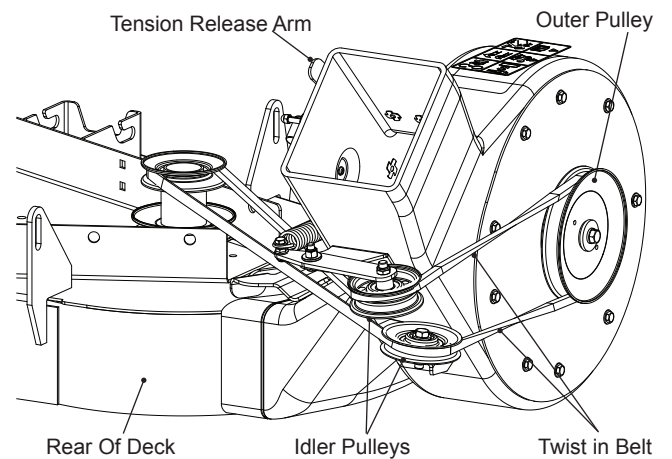

ASSEMBLY

BELT COVERS

1. Place the deck belt shield on the deck over the drive pulley and secure with hardware removed from steel belt shield.
2. Place retainer on the outer pulley cover.
3. Align the tab end of the belt cover into the slot on the deck belt shield and the other end over the end of the outer pulley cover.
4. Secure with knob.

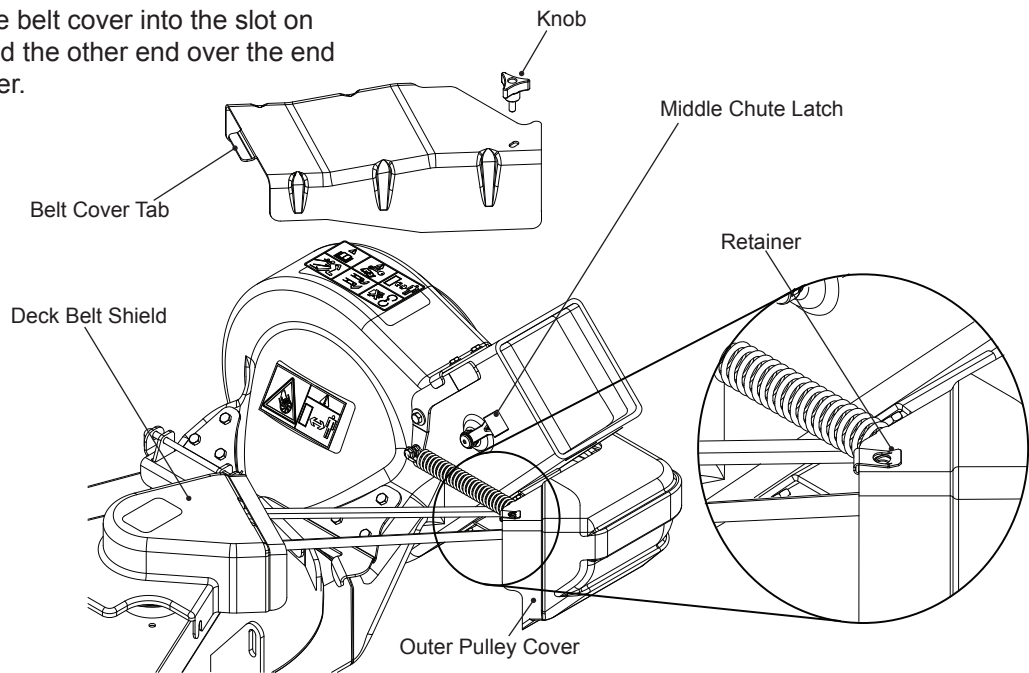

MIDDLE CHUTE

1. Place middle chute over the top end of the blower assembly.
2. Latch middle chute to blower assembly.

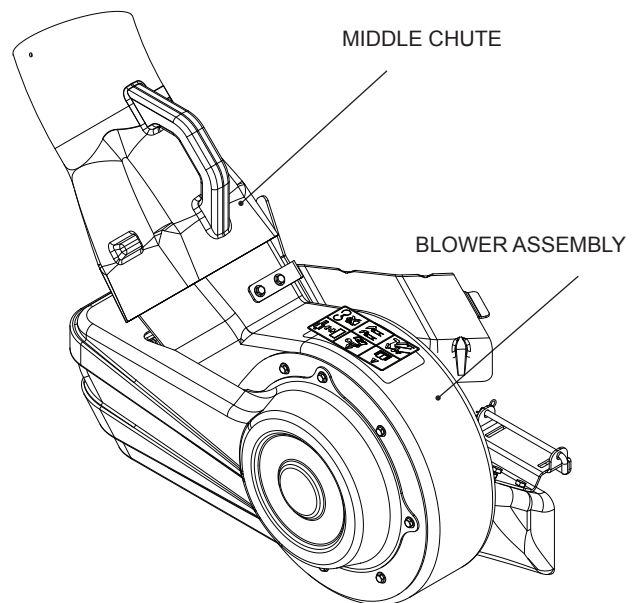

ASSEMBLY

WEIGHT KIT

1. Bolt cast weight and two weight brackets together using $2\frac{3}{4}$ " bolts and nuts.
2. Slide both weight brackets over the front tube on the frame, positioning the assembly in the center of the frame.
3. Secure with $3\frac{3}{4}$ " bolts and nuts.

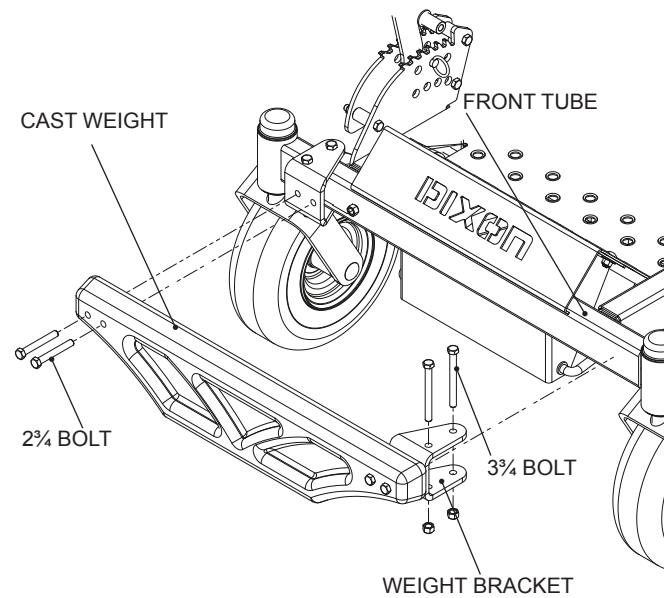

SERVICE AND MAINTENANCE

TRANSPORT



WARNING!

The collection system bags must be completely empty or removed while driving forward onto a trailer. If the mower must be loaded onto a trailer while there is still debris in the container, the mower must be backed up onto the trailer to avoid tipping.

STORAGE

When grass catcher is to be stored for a period of time, clean it thoroughly, remove all dirt, grass, leaves, etc. Store in a clean, dry place. Also clean machine and cover all scratches with touch-up paint. Covered or indoor storage is recommended.

HOSE CARE

1. Inspect hoses before each use. If hoses have excessive wear, tears, or punctures, replace immediately.
2. To prolong the life of the hose, periodically rotate hose and turn hose end to end. Refer to Preventative Maintenance Schedule in this manual.
3. Avoid twists and sharp turns in the hoses, as they will increase wear on the hoses.
4. Avoid dragging the lower hose along the sides of buildings or other hard surfaces

BAG CARE

Inspect the bags before each use. If bags have excessive wear, tears or punctures, replace immediately.

NOTE: Under normal usage the bag material is subject to deterioration and wear.

POLY MESH CLEANING

The poly mesh on the collection system is located inside the container hood. For best results, clean poly mesh regularly.

1. Shut off engine.
2. Release the two (2) rubber latches under the rear of the hood. Open hood and brush debris off of both sides.
3. Close hood and relatch.

DO NOT USE THE COLLECTION SYSTEM WITHOUT POLY MESH SECURELY IN PLACE.

SERVICE AND MAINTENANCE

PREVENTATIVE MAINTENANCE SCHEDULE

	Before Each Use	Every 5 Hours	Every 25 Hours	Every 55 Hours
Inspect/Clean Poly Mesh	X	X		
Check/Tighten Nuts & Bolts	X			
Check/Tighten Hoses	X			
Turn Hose End to End			X	
Rotate Hose				X
Clean Machine				X
Inspect Bags	X			

TROUBLESHOOTING GUIDE

Problem	Possible Cause	Correction
Loss of Vacuum	Blower, hose or hood inlet clogged	Remove hose and clean inlet
	Bags full	Inspect and empty
	Fan blades bent or broken	Replace/repair blower impeller
	Poly mesh plugged	Clean poly mesh
Unusual vibration or noise	Solid object jammed in unit	Check and remove any obstruction
	Loose or missing bolts on unit	Tighten or replace bolts
	Bent or damaged fan	Replace/repair impeller
Unit difficult to close	Obstructions keeping door from completely closing	Clear obstruction
	Hood hinge bolts too tight	Loosen bolts



WARNING!

Before servicing unit, wait for all moving parts to come to a complete stop. Turn engine off and remove the spark plug wire.

OPERATION

TIPS FOR IMPROVED BAGGING

Follow the mower operation instructions in the mower operator's manual.

When utilizing the grass catcher on a lawn where grass and leaf bagging equipment has not been used, thatch and debris that has accumulated for long periods of time will be picked up. The amount collected and the total time of operation may be greater than experienced with regular use of the grass catcher.

- Always run throttle at full speed when bagging.
- Select a speed low enough to give good mower cutting performance, good quality cut and good bagging performance.

NOTE: It may be necessary to overlap width of cut to suit your conditions.

- If grass is extremely tall, it should be mowed twice. The first time relatively high, the second time to desired height.
- Use left hand side of mower for trimming.
- Plastic trash bags (3.0 mil, 30 gallon) can be inserted inside grass catcher containers for ease of debris disposal. To remove the plastic trash bags when full:
 - a. Disengage blades, shift into neutral, engage the parking brake and stop the engine.
 - b. Unlatch and raise cover.
 - c. Remove one container at a time by grasping container handles and pulling toward the rear, off of the tube rails.
 - d. With the container resting on the ground, close and secure the top of the plastic lawn bag.
 - e. Tip the container on its side and slide the filled bag from the container.
 - f. Install a new plastic lawn bag with the edges of the bag draped over upper lip of the container.
 - g. Repeat for other container.
 - h. Reinstall containers making sure right container overlaps left container at center supports.
 - i. Close cover and secure latches over center support tubes.

- Avoid cutting wet grass or mowing in the morning while the dew is still heavy. Grass clippings collected under these conditions tend to be sticky and adhere to the walls of the flow path causing clogging.
- If the grass catcher fails to pick up cut grass or leaves, it is an indication that clogging has occurred in the system or that the grass catcher containers are full.
 - a. Disengage blades, place motion control levers in neutral position.
 - Unlatch and raise cover.
 - Slide out containers and dispose of clippings.
 - Replace containers, close cover, and latch.
 - b. Unlatch chutes and check for clogging.
 - Remove all debris in chute.
 - Reassemble and latch chutes.



WARNING!

- **DO NOT operate mower with grass catcher partially installed.**
- **Disengage blades and stop engine before leaving mower seat to empty containers, unclogging chutes, etc.**
- **Close cover before starting.**
- **Disengage mower blades when crossing driveways or gravel surfaces and other areas where thrown objects could be a hazard.**
- **DO NOT attempt to vacuum up cans or other potentially hazardous projectiles.**

CUSTOMER RESPONSIBILITIES

GENERAL RECOMMENDATIONS

Always observe safety rules when performing any maintenance.

- Before each use check for loose fasteners.
- Clean unit thoroughly after each use.

BLADE CARE

For best results mower blades must be kept sharp.
Replace bent or damaged blades.

- See BLADE CARE instructions in your mower operator's manual.



WARNING!

Grass catcher components are subject to wear, damage and deterioration, which could expose moving parts or allow objects to be thrown. Frequently check components and replace with manufacturer's recommended parts when necessary.



WARNING!

BEFORE ASSEMBLING GRASS CATCHER TO MOWER:

- Set parking brake.
- Place motion control levers in "NEUTRAL" position.
- Turn ignition key "OFF" and remove key.
- Make sure the blades and all moving parts have completely stopped.
- Disconnect spark plug and place wire where it cannot come in contact with plug.



WARNING!

Do not leave grass in bagger containers. Empty containers after each use and before storing. Failure to do so may result in spontaneous combustion which could develop into a fire.

HOOD

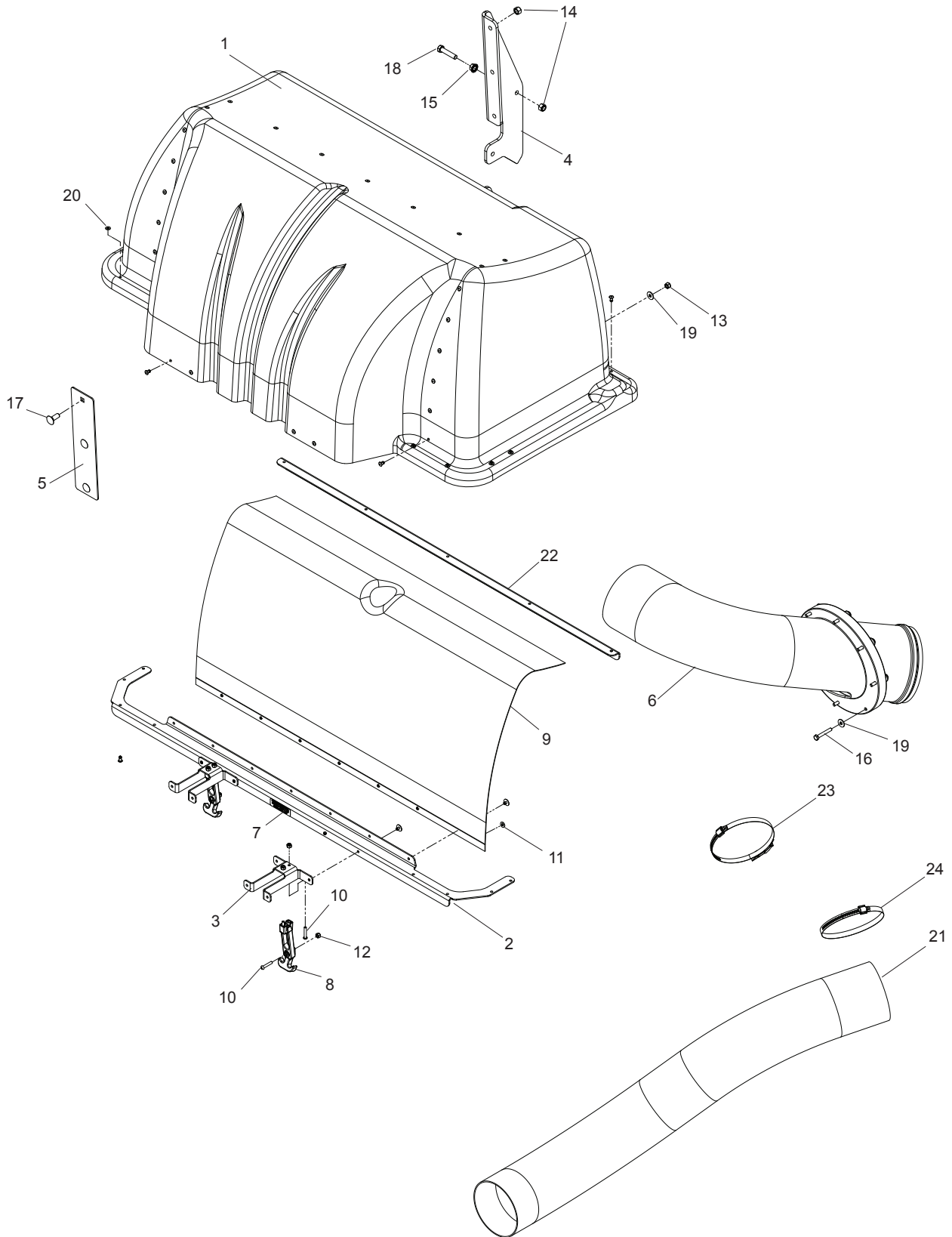

HOOD

ITEM	PART NO.	QTY	DESCRIPTION	ITEM	PART NO.	QTY	DESCRIPTION
1..	539 111172 1....	HOOD	13..	539 976978 8....	NUT 1/4-20 NYLOC
2..	539 111174 1....	SUPPORT, HOOD	14..	539 976979 8....	NUT 3/8-16 NYLOC
3..	539 111175 2....	SUPPORT, DRAW LATCH	15..	539 990613 2....	NUT 3/8-16 WHIZLK
4..	539 111177 2....	HINGE, HOOD	16..	539 991003 8....	HCS 1/4-20 x 1 3/4
5..	539 111181 2....	PLATE, MOUNT	17..	539 990645 6....	RHSNB 3/8-16 x 1
6..	539 111182 1....	TUBE, INLET	18..	539 990730 2....	HCS 3/8-16 x 1 3/4
7..	539 111260 1....	DECAL, VENTILATION	19..	539 990598	.. 16....	WASHER 1/4
8..	539 200478 2....	DRAW LATCH	20..	539 110033 8....	WASHER #10
9..	539 111183 1....	MESH, POLY DIAMOND	21..	523 000201 1....	HOSE 42"
10..	539 111186 6....	SCREW #10-24 x 1 1/8	22..	539 111339 1....	HOOD SUPPORT, REAR
11..	539 105408	.. 21....	WASHER #10	23..	539 109901 1....	BAND, RETAINER w/HASP
12..	539 976977 6....	NUT #10-24 NYLOC	24..	539 097076 1....	BAND, OVER CENTER

HITCH

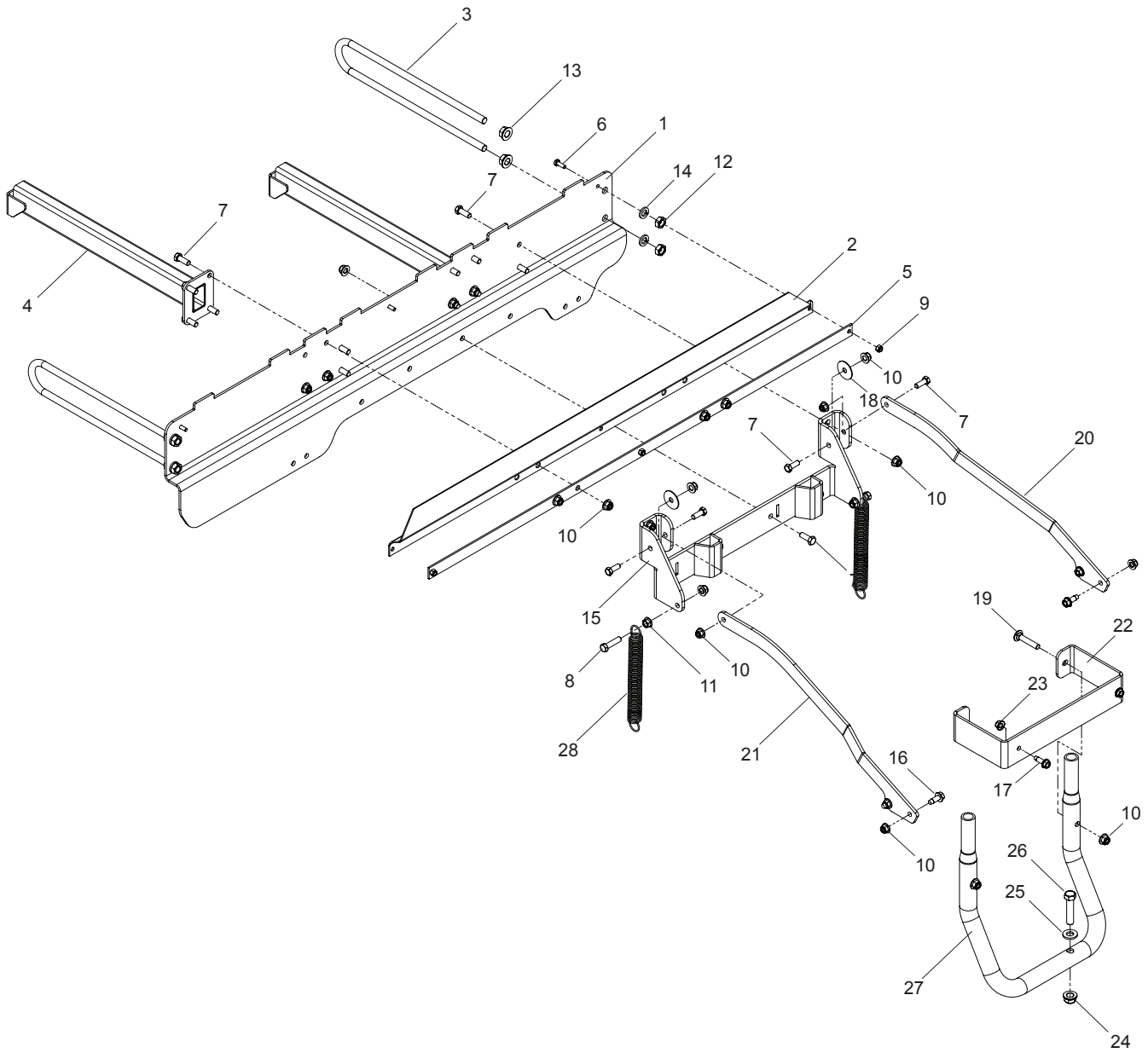

HITCH

ITEM	PART NO.	QTY	DESCRIPTION	ITEM	PART NO.	QTY	DESCRIPTION
1..	539 111157 1....	MOUNT Z BRACE	15..	522 910802 1....	MOUNT, HITCH
2..	539 111167 1....	SEAL, RUBBER	16..	539 107476 4....	BOLT ³ / ₈ -16 THD FRM
3..	539 111158 2....	SUPPORT, OUTER	17..	539 113226 2....	BOLT ⁵ / ₁₆ -18 THD FRM
4..	539 111162 2....	ARM, SUPPORT	18..	539 102998 2....	WASHER, FRICTION
5..	539 111171 1....	STRAP, SEAL	19..	539 100145 2....	RHSNB ³ / ₈ -16 x 2
6..	539 990580 3....	HCS ¹ / ₄ -20 x ³ / ₄	20..	522 910302 1....	STRAP, RT
7..	539 990563	.. 20....	HCS ³ / ₈ -16 x 1	21..	522 910202 1....	STRAP, LT
8..	539 990655 2....	HCS ³ / ₈ -16 x 1 ¹ / ₂	22..	522 910502 1....	BRACKET, SUPPORT
9..	539 976978 3....	NUT ¹ / ₄ -20 NYLOC	23..	539 112899 2....	NUT ⁵ / ₁₆ -18 HEX FLG NYLOC
10..	521 996501	.. 28....	NUT ³ / ₈ -16 HX FLNGE NYLOC	24..	521 991101 1....	NUT ¹ / ₂ -13 HEX FLG NYLOC
11..	539 990613 2....	NUT ³ / ₈ -16 HEX WHIZLK	25..	539 990250 1....	WASHER ¹ / ₂ SAE FLAT
12..	539 990625 4....	NUT ¹ / ₂ JAM	26..	539 107706 1....	HCS ¹ / ₂ -13 x 2 ¹ / ₄
13..	539 111187 4....	NUT ¹ / ₂ -13 HEX WHIZLK	27..	522 910402 1....	TUBE, HITCH
14..	539 990254 4....	WASHER ¹ / ₂ SLW	28..	539 111191 2....	SPRING

BLOWER

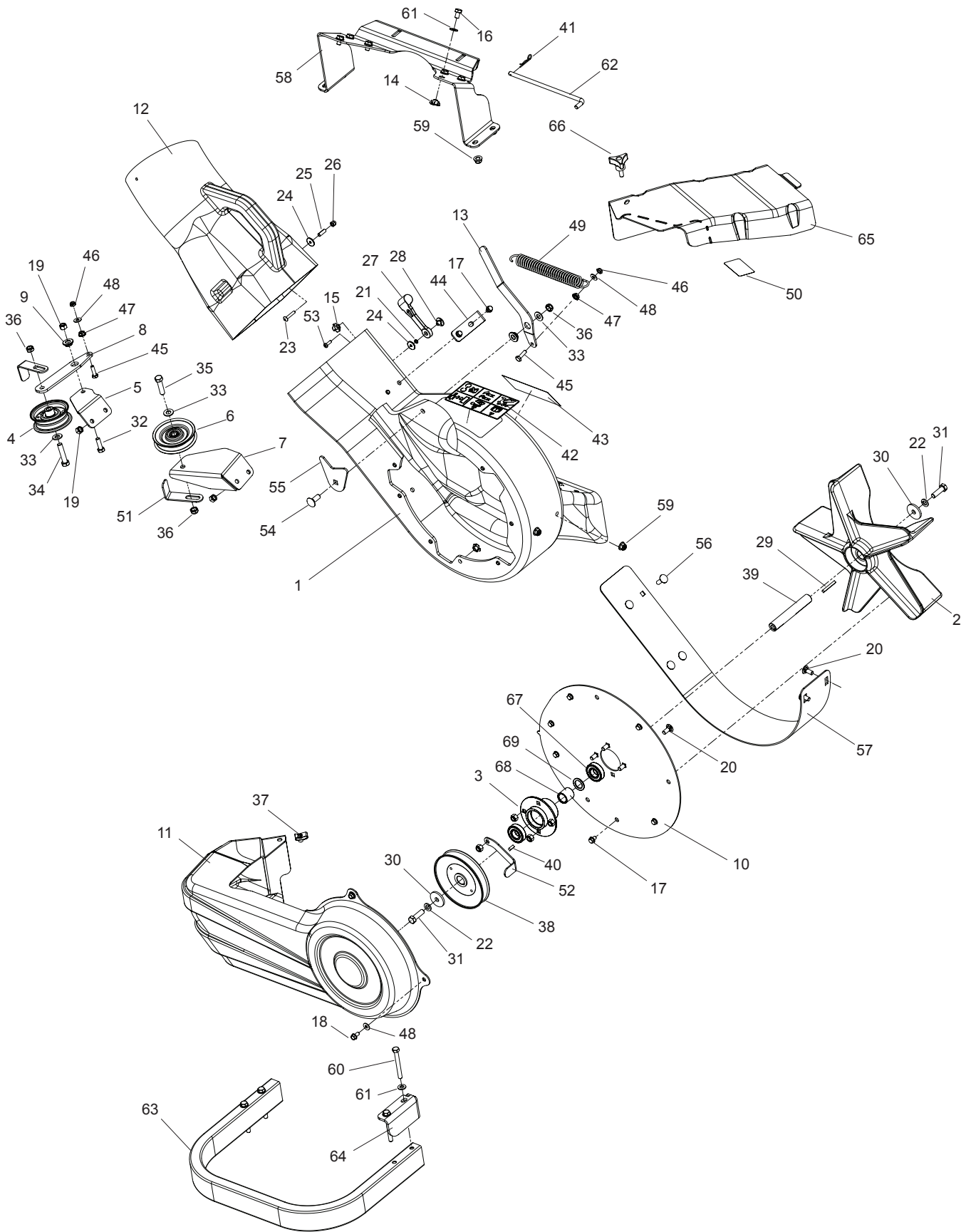

BLOWER

ITEM	PART NO.	QTY	DESCRIPTION	ITEM	PART NO.	QTY	DESCRIPTION
1..	539 130344....	1....	HOUSING w/DECALS	36..	539 200282....	3....	NUT $\frac{3}{8}$ -16 HEX JAM NYLOC
2..	539 130292....	1....	IMPELLER	37..	539 104763....	1....	RETAINER, U TYPE
3..	539 130295....	1....	HUB	38..	539 130324....	1....	PULLEY
4..	539 919078....	1....	PULLEY, IDLER	39..	539 130316....	1....	SHAFT, IMPELLER
5..	539 130335....	1....	MOUNT, IDLER, UPPER	40..	539 115667....	1....	KEY $\frac{3}{16}$ x $\frac{1}{2}$
6..	539 113683....	1....	V-IDLER	41..	539 976988....	1....	HAIRPIN COTTER
7..	539 130336....	1....	MOUNT, IDLER, LOWER	42..	539 105785....	1....	DECAL, WARNING
8..	539 130337....	1....	ARM, IDLER	43..	539 106741....	1....	DECAL, SEVERING
9..	539 130301....	2....	BUSHING	44..	539 130346....	1....	KEEPER
10..	539 130341....	1....	PLATE, OUTER	45..	539 990643....	2....	HCS $\frac{1}{4}$ -20 x $\frac{7}{8}$
11..	539 130293....	1....	COVER, BELT	46..	539 108120....	2....	NUT $\frac{1}{4}$ -20 HEX THIN NYLOC
12..	522 909301....	1....	CHUTE, MIDDLE	47..	539 108735....	2....	NUT $\frac{1}{4}$ -20 HEX FLANGE LK
13..	539 130338....	1....	ARM, TENSION	48..	539 990055....	5....	WASHER $\frac{1}{4}$ FLAT SAE
14..	539 130313....	6....	NUT $\frac{5}{16}$ -18 TEE	49..	539 101977....	1....	SPRING, TRACTION
15..	539 130314....	11....	NUT $\frac{1}{4}$ -20 TEE	50..	539 130349....	1....	DECAL, BELT ROUTING
16..	539 130315....	6....	HCS $\frac{5}{16}$ -18 x $\frac{1}{2}$	51..	539 131087....	2....	KEEPER, BELT, REAR
17..	539 990302....	8....	SCREW $\frac{1}{4}$ -20 x $\frac{3}{8}$ THD FRM	52..	539 131085....	1....	KEEPER, BELT, OUTER
18..	539 108461....	3....	BOLT $\frac{1}{4}$ -20 x $\frac{1}{2}$ HWST	53..	539 976952....	1....	SCREW #10-24 x .625 MACH.
19..	539 990717....	9....	NUT $\frac{5}{16}$ -18 HEX NYLOC	54..	539 990645....	1....	RHSNB $\frac{3}{8}$ -16 x 1
20..	539 990316....	6....	RHSNB $\frac{5}{16}$ -18 x $\frac{3}{4}$	55..	539 132124....	1....	PLATE, BACKING
21..	539 109552....	1....	WASHER $\frac{3}{16}$ SLW	56..	539 990208....	4....	RHSNB $\frac{5}{16}$ -18 x 1
22..	539 990118....	2....	WASHER $\frac{3}{8}$ SLW	57..	522 909702....	1....	LINER, SAND
23..	539 108083....	1....	SCREW, #10- 24 x $1\frac{1}{8}$	58..	522 909602....	1....	BRACKET, MOUNT
24..	539 108084....	2....	WASHER $\frac{3}{16}$ x $\frac{3}{4}$ x 16 GA	59..	539 112899....	2....	NUT $\frac{5}{16}$ -18 HEX FLG NYLOC
25..	539 108085....	1....	SPACER, SPLIT	60..	539 101721....	4....	HCS $\frac{5}{16}$ -18 x $2\frac{3}{4}$
26..	539 108086....	1....	NUT, ACORN #10- 24	61..	539 990188..	10....	WASHER $\frac{5}{16}$ SAE FLAT
27..	539 108088....	1....	LATCH, HOOD	62..	522 909801....	1....	PIN, RETENTION
28..	539 108089....	1....	NUT, PLATED	63..	522 909402....	1....	TUBE, RUB
29..	539 125229....	1....	KEY $1\frac{1}{2}$	64..	522 909502....	1....	BRACKET, RETENTION
30..	539 110323....	2....	WASHER, HARDENED	65..	539 130309....	1....	COVER, BELT
31..	539 110321....	2....	BOLT $\frac{3}{8}$ -24 x $1\frac{1}{4}$ HEX GR 8	66..	539 104411....	1....	KNOB w/STUD
32..	539 990209....	1....	HCS $\frac{5}{16}$ -18 x 1	67..	539 130296....	2....	BEARING
33..	539 990122....	3....	WASHER $\frac{3}{8}$ SAE FLT	68..	539 130323....	1....	SPACER
34..	539 976949....	1....	HCS $\frac{3}{8}$ -16 x $1\frac{3}{4}$	69..	539 910935....	1....	WASHER $\frac{3}{4}$ FLAT
35..	539 990655....	1....	HCS $\frac{3}{8}$ -16 x $1\frac{1}{2}$				

WEIGHT

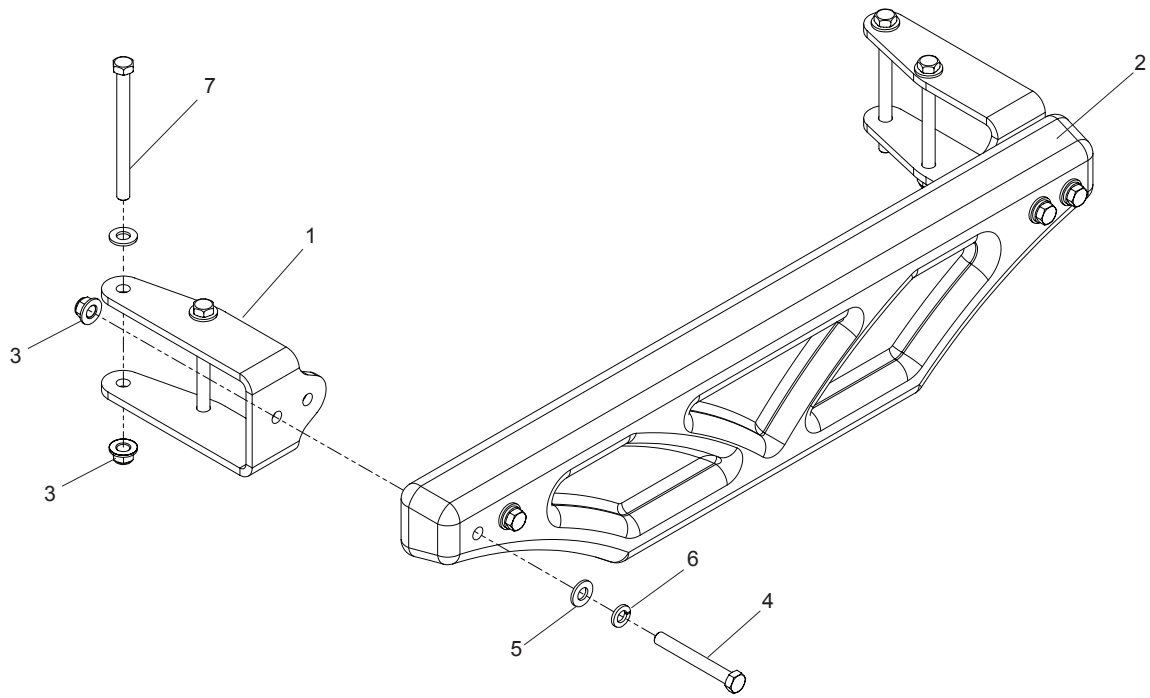

COLLECTION BAG

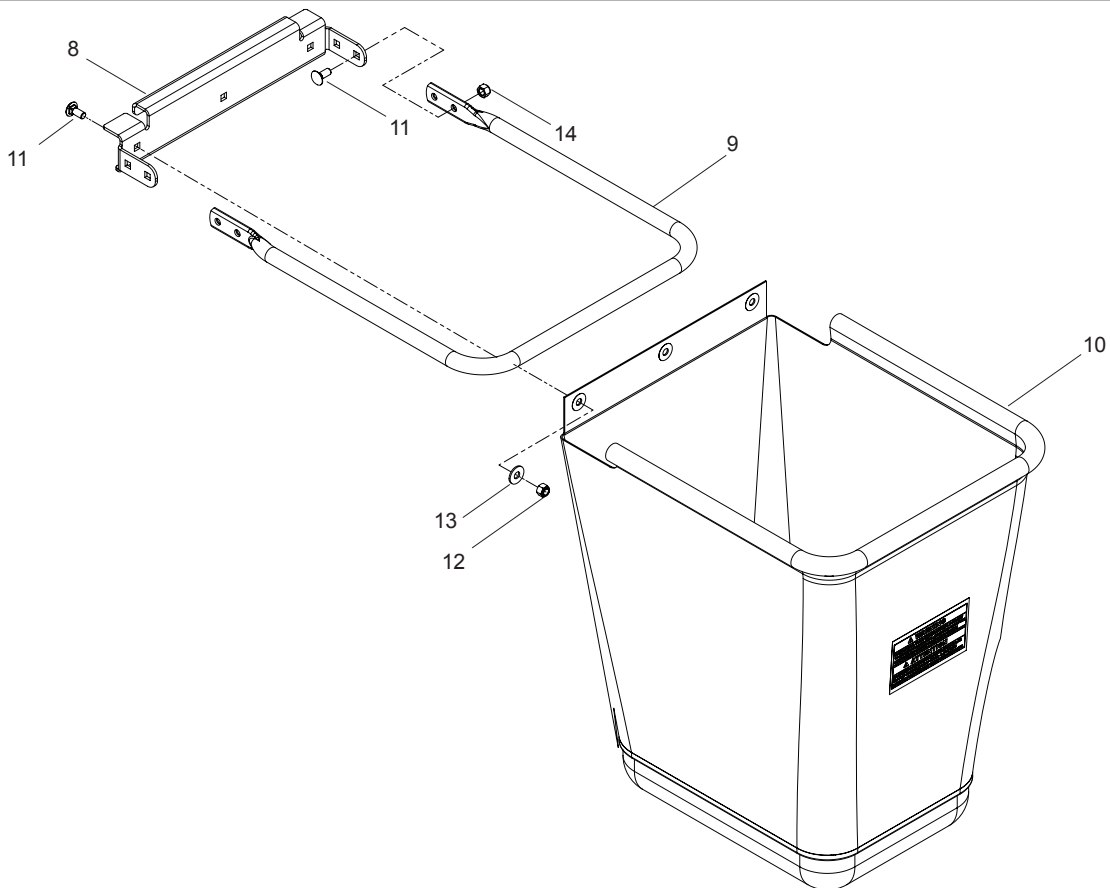

WEIGHT

ITEM	PART NO.	QTY	DESCRIPTION	ITEM	PART NO.	QTY	DESCRIPTION
1..	522 989002....	1....	BRACKET, WEIGHT	5..	539 990122....	8....	WASHER $\frac{3}{8}$ SAE FLAT
2..	539 111587	1....	WEIGHT, CAST	6..	539 990118....	4....	WASHER $\frac{3}{8}$ SLW
3..	521 996501....	8....	NUT $\frac{3}{8}$ -16 HEX FLANGE	7..	539 102334....	4....	HCS $\frac{3}{8}$ -16 x 4 $\frac{1}{2}$
4..	539 101341....	4....	HCS $\frac{3}{8}$ -16 x 3				

COLLECTION BAG

8..	539 110063....	3....	HANGER, BAG	11..	539 990316..	21....	RHSNB $\frac{5}{16}$ -18 x $\frac{3}{4}$
9..	539 111166	3....	TUBE, BAG FRAME	12..	539 990717..	21....	NUT $\frac{5}{16}$ -18 NYLOC
10..	539 111300	3....	BAG, SMALL	13..	539 990692....	9....	WASHER $\frac{5}{16}$

DRIVE KIT

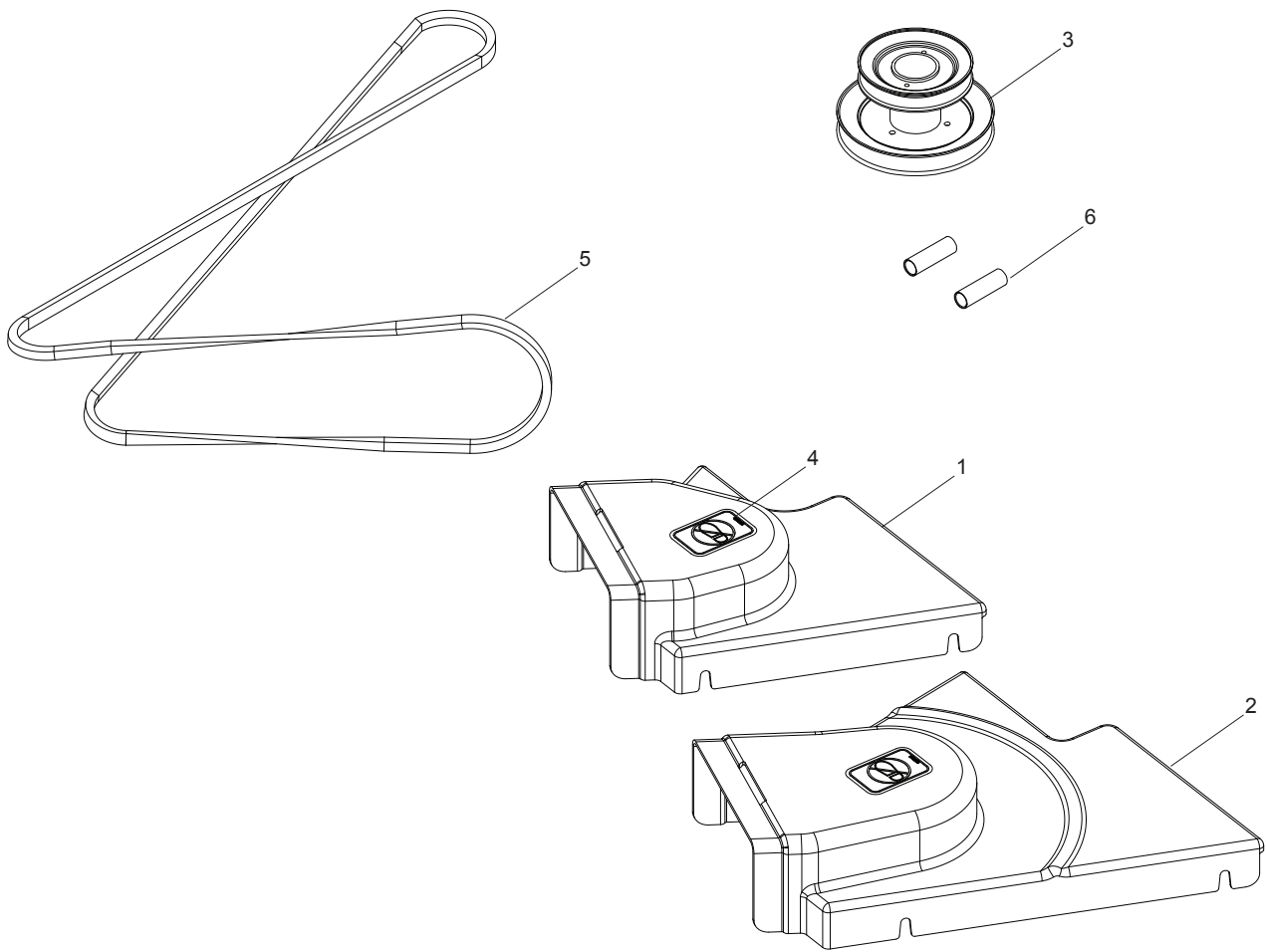

DRIVE KIT

- | | |
|--------------------------------------------|------------------------------------------|
| 1.. 539 130307.... 1.... SHIELD, BELT, 52" | 4.. 539 105743.... 1.... DECAL, NO STEP |
| 2.. 539 130308.... 1.... SHIELD, BELT, 61" | 5.. 539 130347.... 1.... BELT, 52" |
| 3.. 522 909901.... 1.... PULLEY, 52" | 539 130348 ... 1.... BELT, 61" |
| 522 910001 ... 1.... PULLEY, 61" | 6.. 523 351701.... 2.... TUBE, DECK STOP |

